

NEWS METS 06

CR63 Freezer

Isotherm by Indel Marine launches a new stainless steel freezer in their INOX range. Cruise 63 is a front opened freezer made in the same outside dimension as Cruise 85 refrigerator to allow side by side installation fridge/freezer. The extra thick insulation gives a very low power consumption, something Isotherm by Indel Marine are well regarded for. Cruise 63 will also be available in a standard version with grey door front. A manual built in icemaker device is also available as option.



H- 625 mm, W-475 mm, D-555 mm

DR65 and DR190

The new drawer refrigerators showed as prototypes at last years Mets are now in production. It makes the drawer DR range complete in following sizes: 36, 65, 105 and 190 litres.



Air heater

The new Isotherm Air Heater 10 kW is a completely new product in our line. Its either connected in the engine cooling circuit to absorb surplus heat from the engine or to a diesel water heater. A fan circulates air through a heat exchanger. There are 4 x 60 mm (55 mm available) ducting and the fan have 3 speeds. The air intake is on the opposite side through two 90 mm hose adapters.

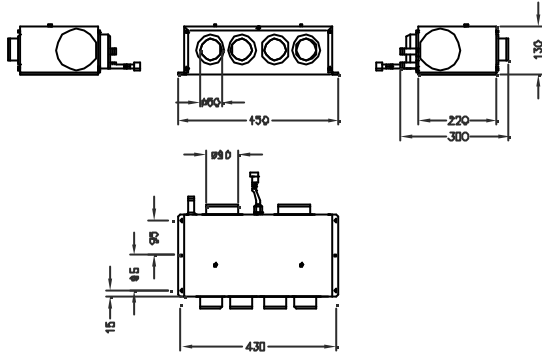

Indel B, China



Indel B is continuing its expansion and also starting up production in China. The new 35.000 m² (700.000 sq.ft) big plant will produce a number of its Isotherm by Indel Marine models, parallel with existing production in Europe. The plant will also produce the high volume products for trucks and hotels in the Indel Group. There is not any production moving to China but starting parallel in identical tools to secure delivery but also stand stronger and more competitive in the future. The new factory will give the opportunity to produce big number of models in the most modern way at the lowest cost. All production and assembly in Italy, Sweden and USA will continue and that gives a flexibility and security that is important especially to our OEM customer's world wide. On the other hand will Indel Marine continue to develop special models, even in small numbers. This is a market that put us in a position where we can supply all type of refrigeration, big or small.

